

A

Y

A



Form follows magic.

selux

Aya

A new generation of luminaires where intelligent, high-end lighting technology meets design modelled on the magic of nature.

With Aya, we provide a solution for ecological issues using the latest scientific findings. The balance between man, nature, design and functionality is reinterpreted to create light for generations. Aya integrates all the functions for future-oriented luminaires and fulfils all requirements for sustainable lighting all while Aya emphasises the natural beauty of urban spaces.



Circular Light Profiles

Light in natural rhythm



Aya combined with our scientifically based »Circular Light Profiles« harmonises people's and nature's needs by adjusting the light colour and intensity depending on the time of year and time of day, saving energy and the environment. This creates a new simplicity that enables all communities to have sustainable lighting solutions in every location. The algorithm is pre-installed in every luminaire onto the Selux Core. There is no need for time-consuming planning and support. The luminaire is delivered and ready to use.

Biological Red Safety with special biodiversity protection

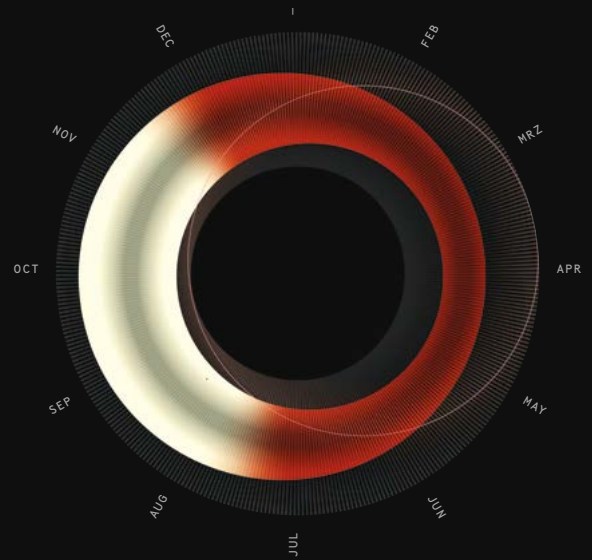

Biological White Safety with biodiversity protection



Adjusting White Orientation for people, dark zones for nature



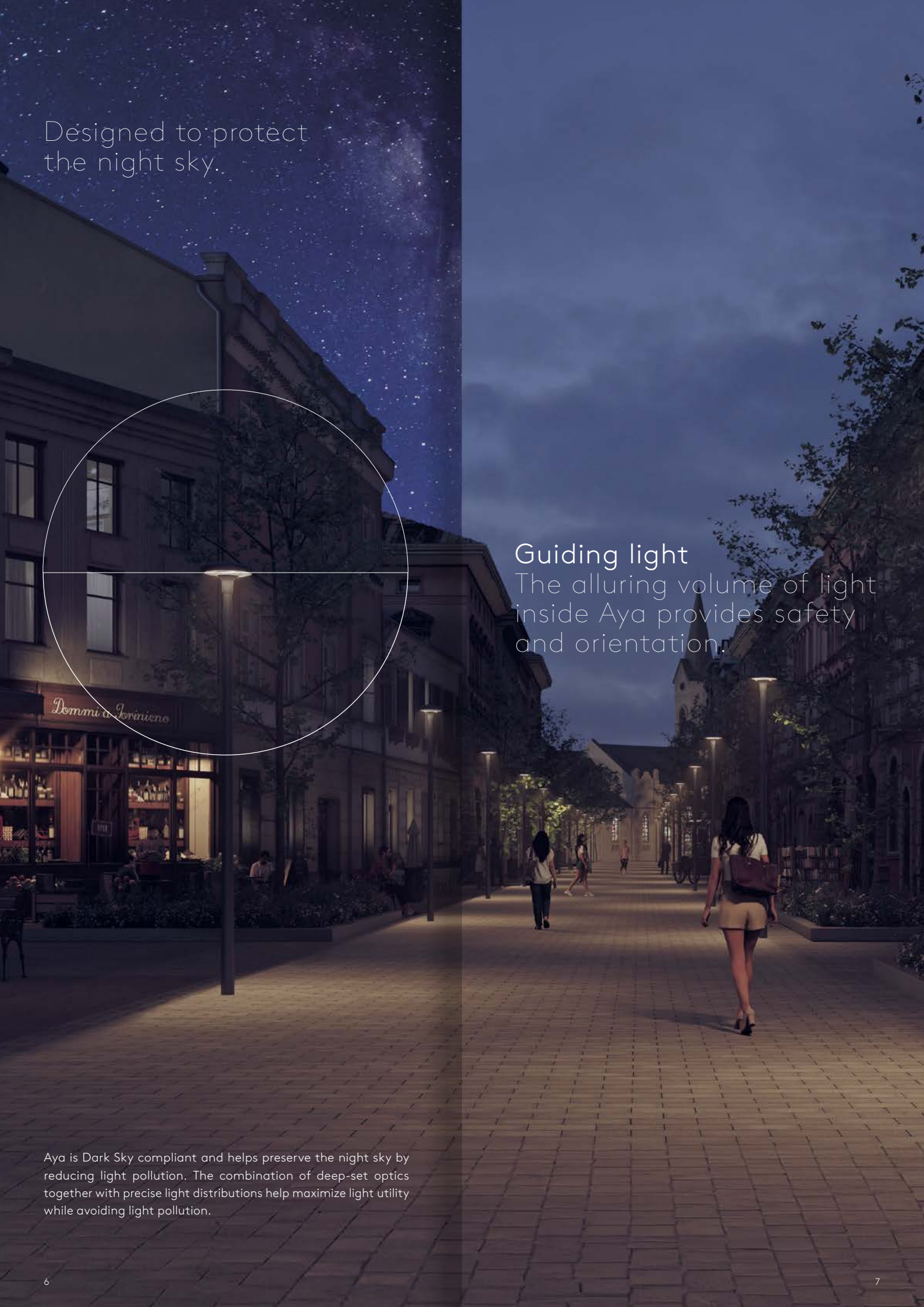

Designed to protect
the night sky.

Guiding light

The alluring volume of light
inside Aya provides safety
and orientation.

Aya is Dark Sky compliant and helps preserve the night sky by reducing light pollution. The combination of deep-set optics together with precise light distributions help maximize light utility while avoiding light pollution.

Self-cleaning through
rainwater – following
nature's example.



The organic form of Aya allows rainwater to float across the entire luminaire housing, from top to bottom. This not only helps clean the luminaire but also improves the maintenance efficiency of the luminaire.

Minimal resources –
Maximum integration.

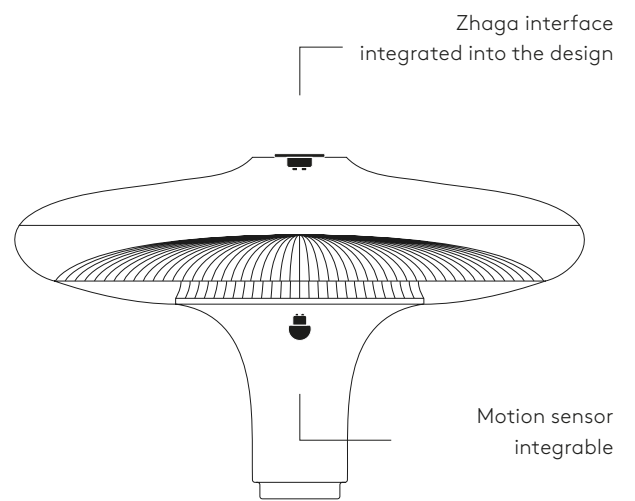

Everything that doesn't work or is unnecessary is filtered out by nature. Following this maxim, Aya's form emerged from its function – with minimal use of materials to conserve resources. The silhouette seamlessly integrates into urban and natural spaces thanks to its soft contours.

Glare-free optics

For visual comfort and greater flexibility.



Specially designed reflector and lens optics, combined with the luminaire's shape, enable controlled light emission. Depending on the arrangement of the modular optics, the light distribution can be either symmetric or asymmetric. The use of glare shields minimises excess spill light. This protects residential areas and environmental zones from unwanted light.

sym. round

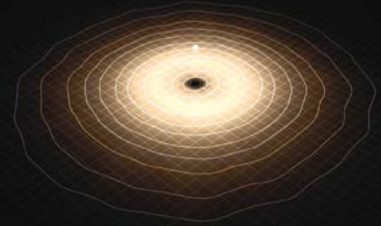

sym. long

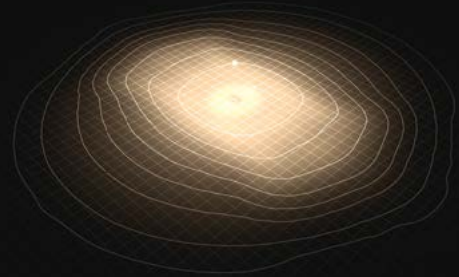

asym. narrow

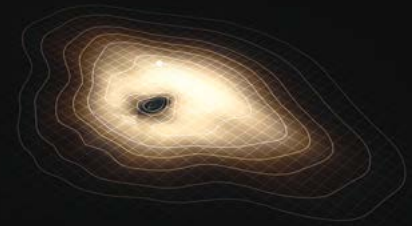

asym. wide

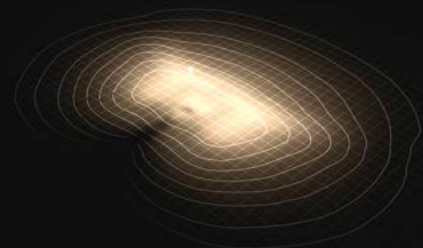

Flexible connection For various pole types.



design pole

Ø 76



conical pole

Ø 60

Dimensions

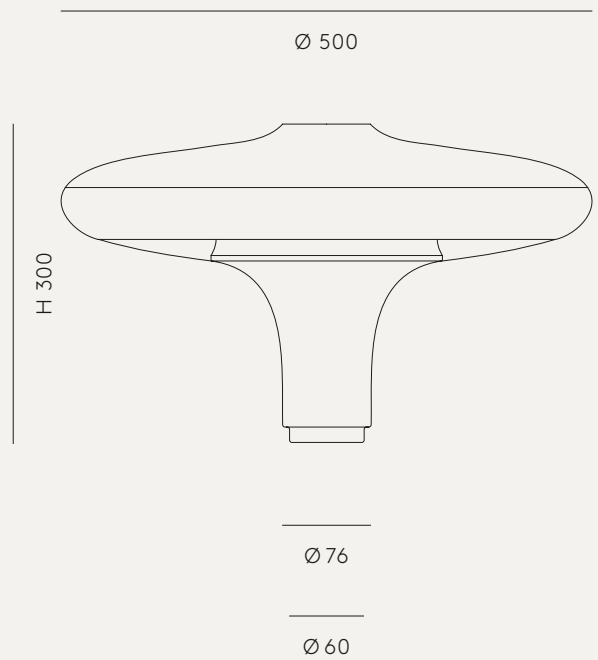

Technical specifications

| | |
|---------------------------|--|
| Ingress protection | IP 65 |
| Protection class | SK II, optional SK I |
| Material | PC moulded body, die-cast aluminium chassis |
| System efficiency | up to 130 lm/W |
| Light color | Biological Red, Biological White, 2200K, 2700K, 3000K, 4000K |
| Driver | 120 - 277V / 50 - 60 Hz |
| Optics | Silver coated reflector |
| Light distribution | sym. round; sym. long, asym. narrow; asym. wide, |
| Pole attachment | 76 or 60 mm |
| Interfaces | DALI |
| Controls | <ul style="list-style-type: none"> · In natural rhythm via Selux Core · Programmed via light management system in conjunction with Zhaga |
| Dimming optics | Fix Dimm, HNS, Dynadimmer, CLT, AmpDim |

Diversity for urban spaces.

Aya

Mounting options

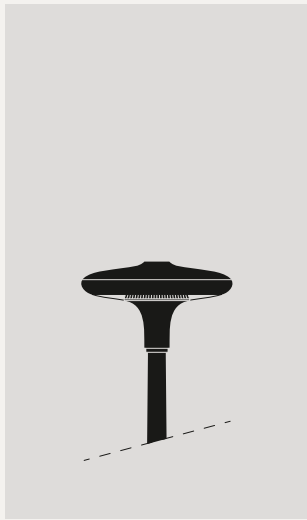

Pole top



Pole pendant

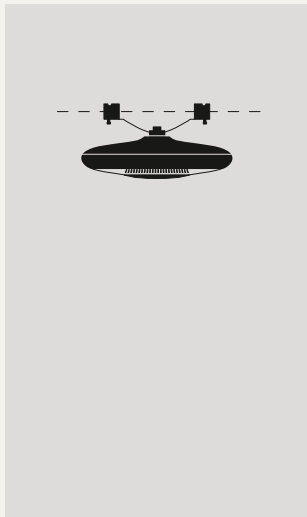

Catenary cable-mounted

With Aya, you can bring consistency to the identity of an urban space through the various installation and mounting options available. The options range from post-top luminaires for residential streets, paths, or squares to mast pendant and cable pendant luminaires for wide streets and large areas, allowing you to maintain a cohesive design concept.

*Post-top luminaires available from Q1/2024,
Mast pendant and cable pendant variants available from Q3/2024.

Editor

Selux GmbH
Volkmarstraße 18
12099 Berlin, Germany
www.selux.com

Responsible for content

Selux GmbH
Volkmarstraße 18
12099 Berlin, Germany
www.selux.com

Concept and design

Selux
Tom Richter &
Manuela Schnabel

Printing and production

Königsdruck
Alt-Reinickendorf 28
13407 Berlin

Selux is a registered trademark of the Selux GmbH.

Errors accepted and subject to change due to technical modifications.

For conditions of sale and delivery please refer to www.selux.com

The use of the text and images, even in part, is in breach of copyright without the consent of the Selux GmbH and punishable. This also applies to copies, translations, microfilming and processing with electronic systems.

10074992
English edition
2024
Printed in Germany

At Selux, we have been asking ourselves how to light places for more than 75 years. How do we create safety, well-being and beauty with light? How do our products work during the day when they are objects in public spaces?

The amazing thing is that the answers to these questions are right in front of us. Nature provides us with the answers. In nature, everything is in harmony. Everything complements each other, nothing dominates in the long run. Nature knows no monoculture, nothing is fashionable and everything that does not make sense will disappear in the end. The results are perfect protagonists that exist in interaction with each other and constantly optimise themselves.

As a result, we have come to a central realisation: Timelessness is the best form of sustainability. We want to create products that we will still find beautiful in decades to come and that function perfectly. Products that enter into a symbiosis with the room and work harmoniously with nature.



When form meets function.
When something new and unprecedented breaks ground.
When we are fascinated by symbiosis.
That's magic.